

**Single Conductor – Weldable**

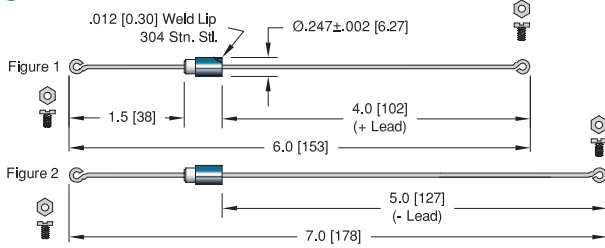

**Single Pair – Weldable**

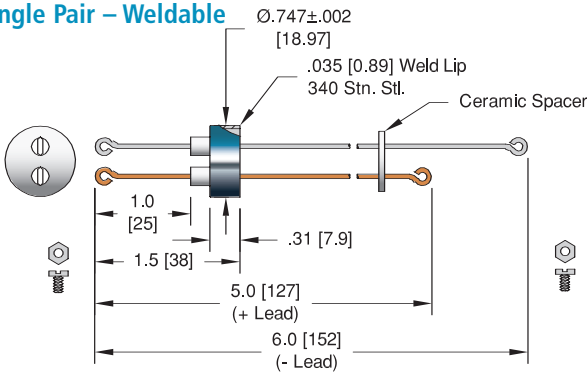

**Single Pair – ISO KF - NW16KF**

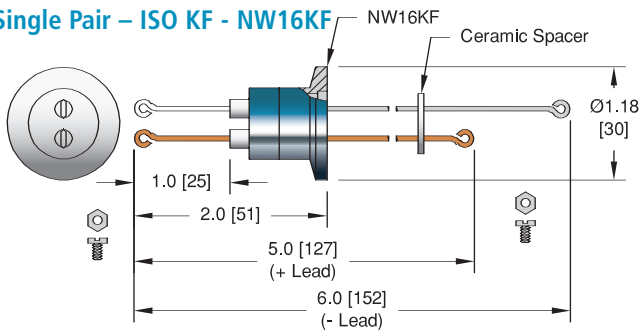

**Single Pair – ConFlat - NW16CF**

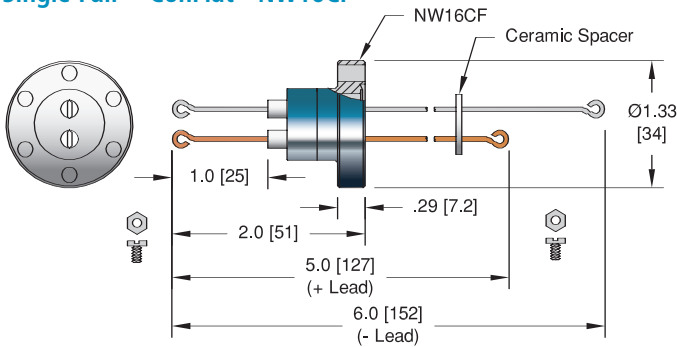

**Single Pair – ConFlat - NW35CF**

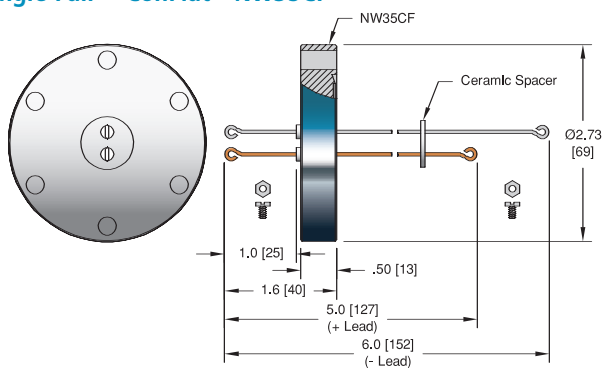

**Two Pairs – Weldable**

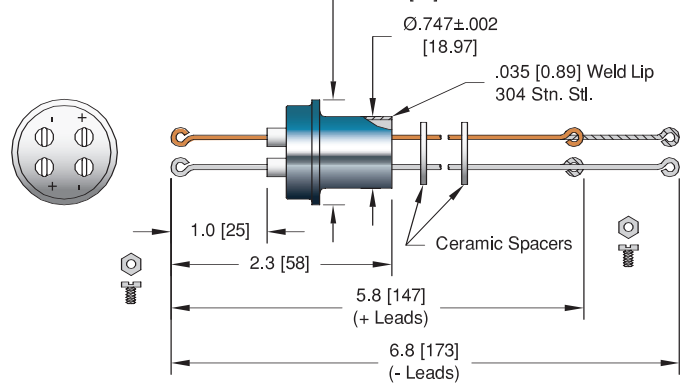

**Two Pairs – ISO KF - NW16KF**

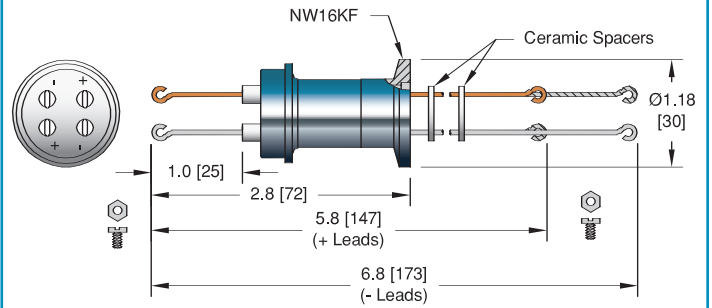

**Two Pairs – ConFlat - NW16CF**

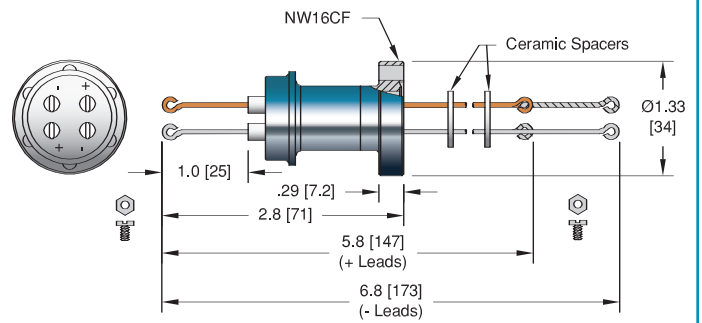

**Two Pairs – ConFlat - NW35CF**

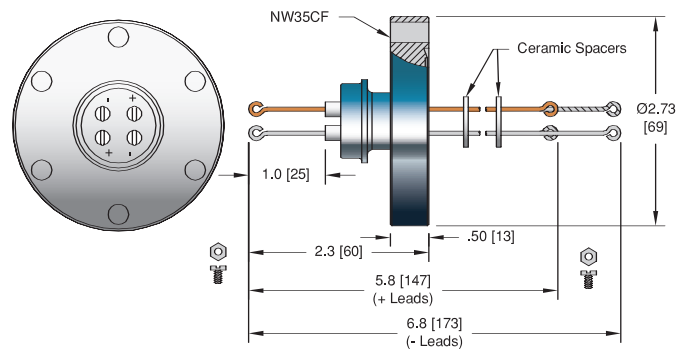



THERMOCOUPLE MATERIAL	FIGURE NUMBER	INSTALLATION	PART NUMBER
Copper	1	Weld	18085-13-W
Constantan	2	Weld	18085-14-W
Platinum-Rhodium*	2	Weld	18085-15-W

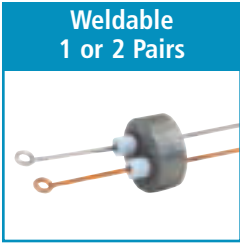

ANSI TYPE	THERMOCOUPLE MATERIALS	INSTALLATION	NO. OF PAIRS	PART NUMBER
T	Copper/Constantan	Weld	1	8900-02-W
R/S	Platinum-Rhodium*	Weld	1	8900-03-W
T	Copper/Constantan	Weld	2	8800-02-W
R/S	Platinum-Rhodium*	Weld	2	8800-03-W



ISO FLANGE				
ANSI TYPE	THERMOCOUPLE MATERIALS	INSTALLATION	NO. OF PAIRS	PART NUMBER
T	Copper/Constantan	NW16KF	1	18004-01-KF
R/S	Platinum-Rhodium*	NW16KF	1	18004-02-KF
T	Copper/Constantan	NW16KF	2	15108-01-KF
R/S	Platinum-Rhodium*	NW16KF	2	15108-02-KF

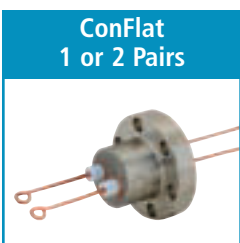

CONFLAT FLANGE				
ANSI TYPE	THERMOCOUPLE MATERIALS	INSTALLATION	NO. OF PAIRS	PART NUMBER
T	Copper/Constantan	1 1/3" (NW16CF)	1	9020-02-CF
R/S	Platinum-Rhodium*	1 1/3" (NW16CF)	1	9020-03-CF
T	Copper/Constantan	2 3/4" (NW35CF)	1	9806-02-CF
R/S	Platinum-Rhodium*	2 3/4" (NW35CF)	1	9806-01-CF
T	Copper/Constantan	1 1/3" (NW16CF)	2	8820-02-CF
R/S	Platinum-Rhodium*	1 1/3" (NW16CF)	2	8820-03-CF
T	Copper/Constantan	2 3/4" (NW35CF)	2	10584-02-CF
R/S	Platinum-Rhodium*	2 3/4" (NW35CF)	2	10584-03-CF

\*Uses compensating wire. Maximum junction temperature 250° C.

### Specifications - Single Conductor

#### Materials

- Shell: 304 Stainless steel
- Thermocouple materials:
  - Copper
  - Constantan
  - Platinum-Rhodium
- Insulation: Alumina ceramic
- Magnetic Materials: No

**Temperature Range** -269°C to 450°C

**Pressure @ 20°C** 3500 PSIG (241 Bar), ISO KF 0 PSIG

### Specifications - 1 or 2 Pairs

#### Materials

- Shell: 304 Stainless steel
- Thermocouple materials:
  - Copper/Constantan (Type T)
  - Platinum-Rhodium (Type R/S)
- Insulation: Alumina ceramic
- Magnetic Materials: No

**Temperature Range** -269°C to 450°C

**Pressure @ 20°C** ISO KF 0 PSIG

- 1 Pair: 1250 PSIG (86 Bar)
- 2 Pairs: 800 PSIG (55 Bar)