

Feedthrough

Specifications

Materials

Housing: 304 Stainless steel
Pin/Tube: See table
Insulation: Alumina ceramic
Magnetic Materials: See table

Voltage Rating See table

Current Rating See table

Temperature Range -269°C to 450°C, ISO KF -25°C to 205°C

Pressure @ 20°C ISO KF 0 PSIG

Single Pin: 3500 PSIG (241 Bar)
2 & 4 Pin: 1250 PSIG (86 Bar)

Multipin Connector

Coaxial

Thermocouple

Isolator

Viewport

Pressure

Accessories

Technical Reference

Weldable - Single Pin

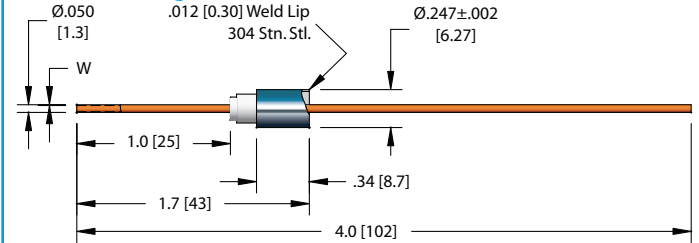

Weldable - 2 & 4 Pin

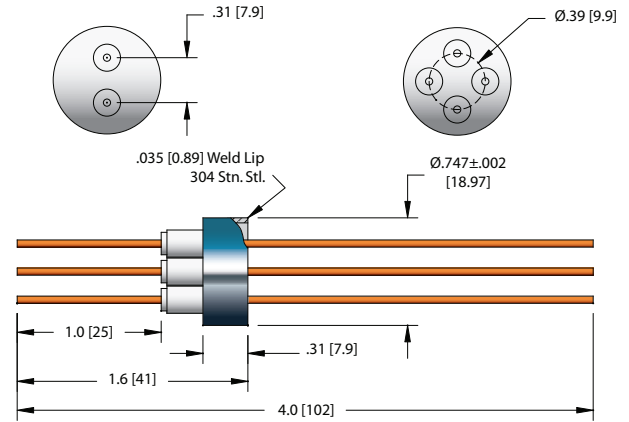

ISO KF - 2 & 4 Pin

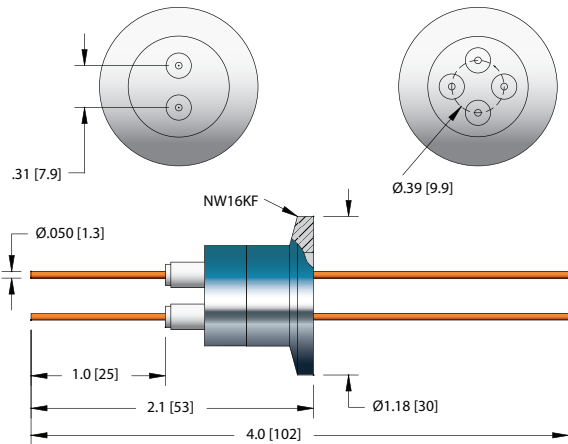

ConFlat - 2 & 4 Pin 6 kV

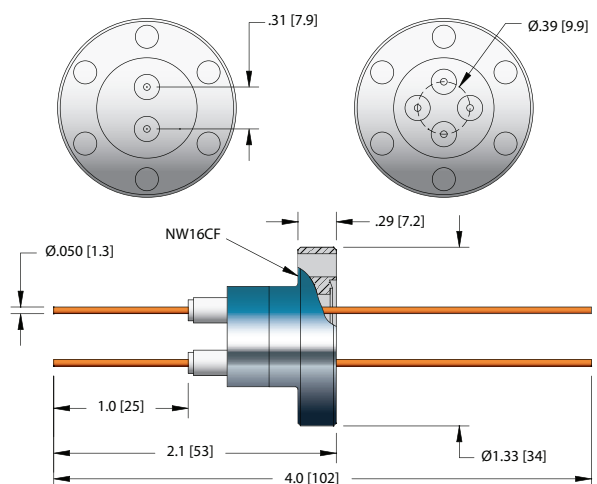

Weldable Single Pin

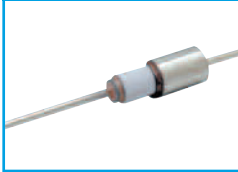

NO. PINS	INSTALLATION	VOLTAGE DC	AMPS*	CONDUCTOR MATERIAL	W	MAGNETIC MATERIALS	PART NUMBER
1	Weld	2 KV	1.8	304 Stn. Stl.	-	No	7844-02-W
1	Weld	2 KV	8.2	Nickel	-	Yes	7844-01-W
1	Weld	2 KV	13.5	Molybdenum	-	No	7844-21-W
1	Weld	2 KV	27	Copper	-	No	7844-04-W
1	Weld	5 KV	1.8	304 Stn. Stl.	-	No	9791-04-W
1	Weld	5 KV	8.2	Nickel	-	Yes	9791-02-W
1	Weld	5 KV	13.5	Molybdenum	-	No	9791-09-W
1	Weld	5 KV	27	Copper	-	No	9791-08-W
1	Weld	5 KV	-	Nickel Tube	.005	Yes	9791-06-W

*Current carrying capacity of the tubular feedthroughs varies based on the coolant used and the flow rate.

Weldable 2 & 4 Pin



2	Weld	6 KV	1.8	304 Stn. Stl.	-	No	9215-04-W
2	Weld	6 KV	8.2	Nickel	-	Yes	9215-02-W
2	Weld	6 KV	13.5	Molybdenum	-	No	9215-14-W
2	Weld	6 KV	27	Copper	-	No	9215-08-W
4	Weld	3 KV	1.8	304 Stn. Stl.	-	No	8177-02-W
4	Weld	3 KV	8.2	Nickel	-	Yes	8177-01-W
4	Weld	3 KV	13.5	Molybdenum	-	No	8177-06-W
4	Weld	3 KV	27	Copper	-	No	8177-04-W
4	Weld	6 KV	1.8	304 Stn. Stl.	-	No	9216-04-W
4	Weld	6 KV	8.2	Nickel	-	Yes	9216-02-W
4	Weld	6 KV	13.5	Molybdenum	-	No	9216-14-W
4	Weld	6 KV	27	Copper	-	No	9216-08-W

ISO FLANGE

ISO KF 2 & 4 Pin

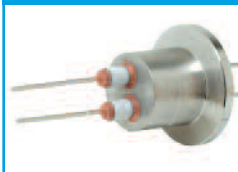

2	NW16KF	6 KV	1.8	304 Stn. Stl.	-	No	17018-01-KF
2	NW16KF	6 KV	8.2	Nickel	-	Yes	17018-02-KF
2	NW16KF	6 KV	27	Copper	-	No	17018-04-KF
4	NW16KF	6 KV	1.8	304 Stn. Stl.	-	No	17019-01-KF
4	NW16KF	6 KV	8.2	Nickel	-	Yes	17019-02-KF
4	NW16KF	6 KV	27	Copper	-	No	17019-04-KF

CONFLAT FLANGE

ConFlat 2 & 4 Pin

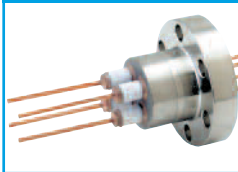

2	1 1/3" (NW16CF)	6 KV	1.8	304 Stn. Stl.	-	No	9871-02-CF
2	1 1/3" (NW16CF)	6 KV	8.2	Nickel	-	Yes	9871-01-CF
2	1 1/3" (NW16CF)	6 KV	27	Copper	-	No	9871-04-CF
4	1 1/3" (NW16CF)	3 KV	8.2	Nickel	-	Yes	8176-02-CF
4	1 1/3" (NW16CF)	3 KV	27	Copper	-	No	8176-08-CF
4	1 1/3" (NW16CF)	6 KV	1.8	304 Stn. Stl.	-	No	9871-06-CF
4	1 1/3" (NW16CF)	6 KV	8.2	Nickel	-	Yes	9871-05-CF
4	1 1/3" (NW16CF)	6 KV	27	Copper	-	No	9871-08-CF

*See page 213 for In-Vacuum Cable (Kapton). See page 195 for Contacts. See the Accessories section for more information on all accessories.

Feedthrough

Multipin Connector

Coaxial

Thermocouple

Isolator

Viewport

Pressure

Accessories

Technical Reference