

DWG. NO. L600A01_EXT		SHT 1/1	REV E	
REVISIONS				
ZONE	REV.	DESCRIPTION	DATE	APPROVED
	E	DRAWING RELEASE	03-20-14	

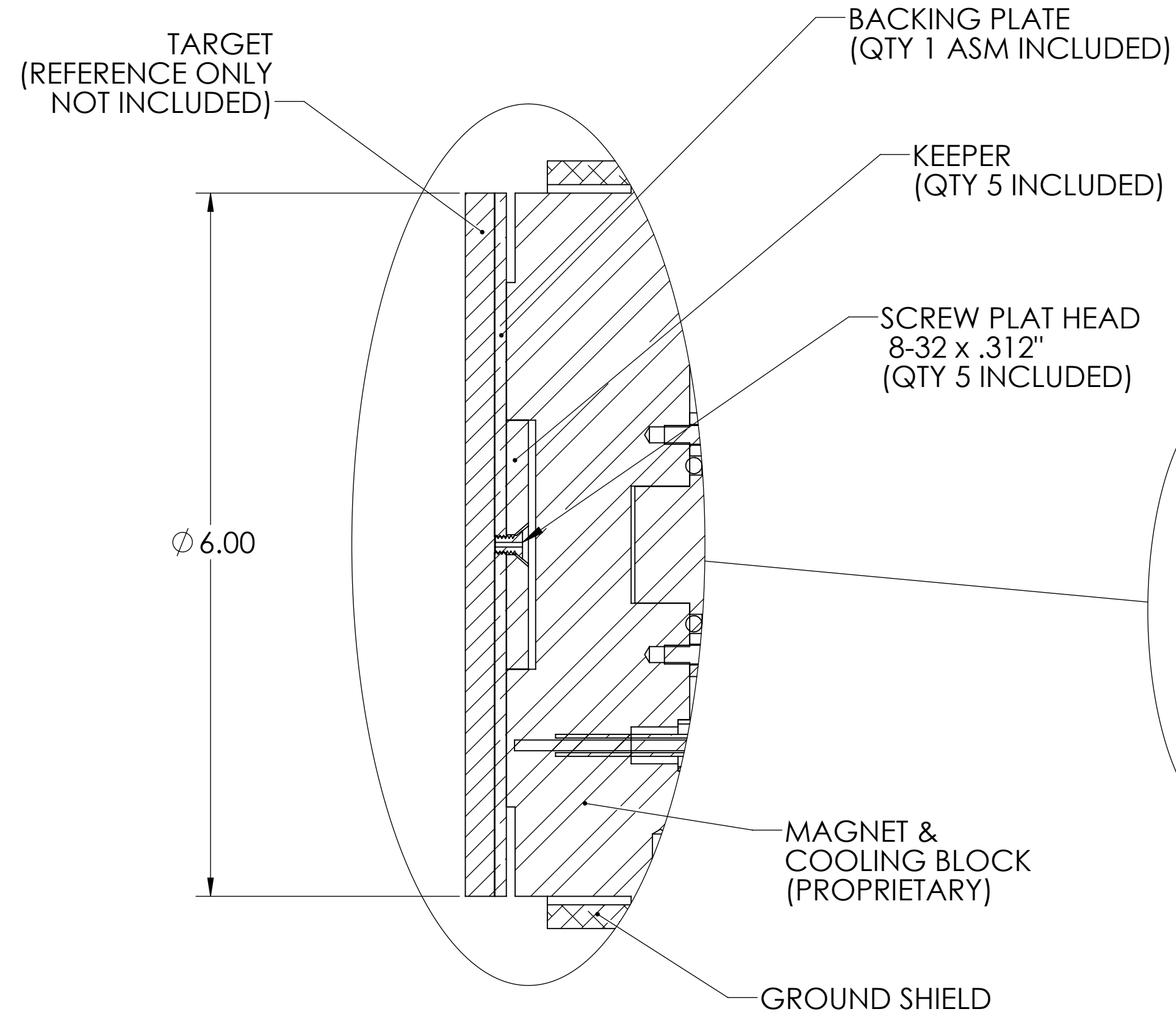

**DETAIL B
SCALE 1 : 1**

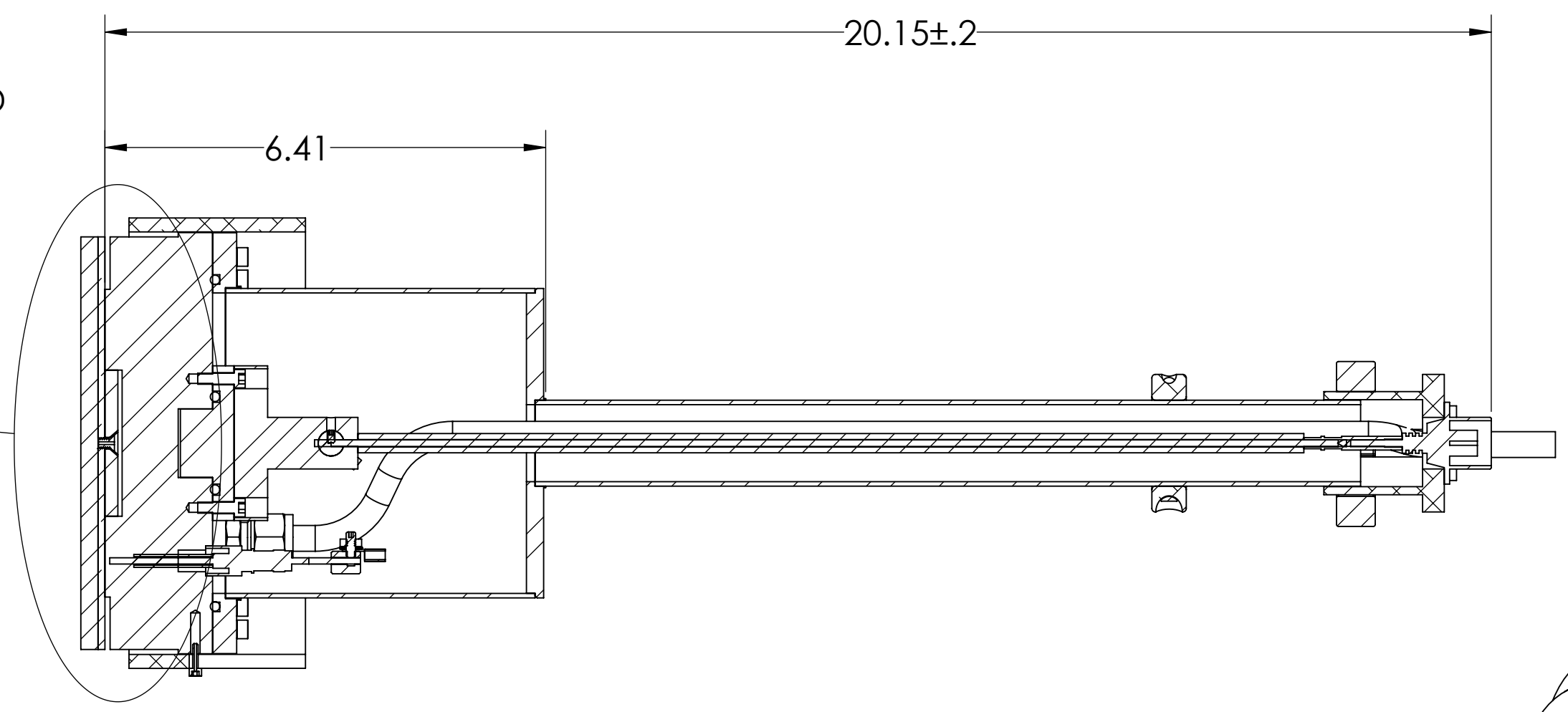

SECTION A-A

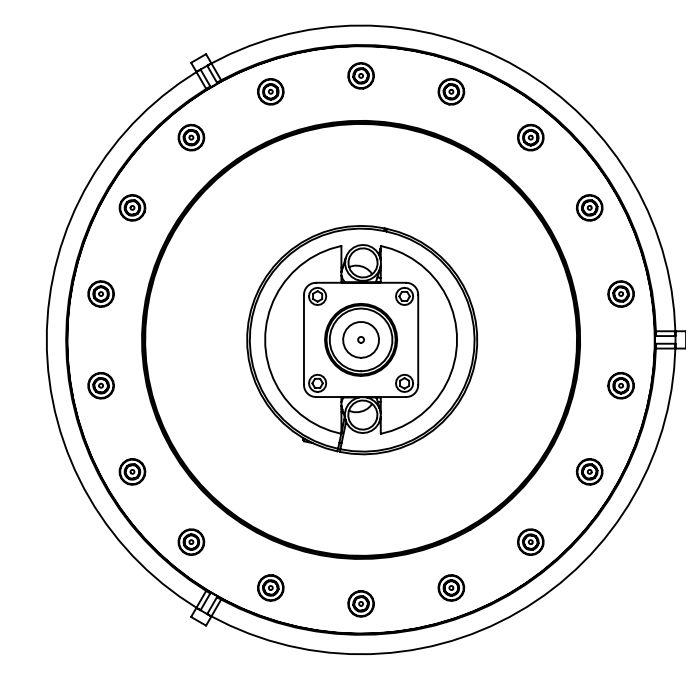
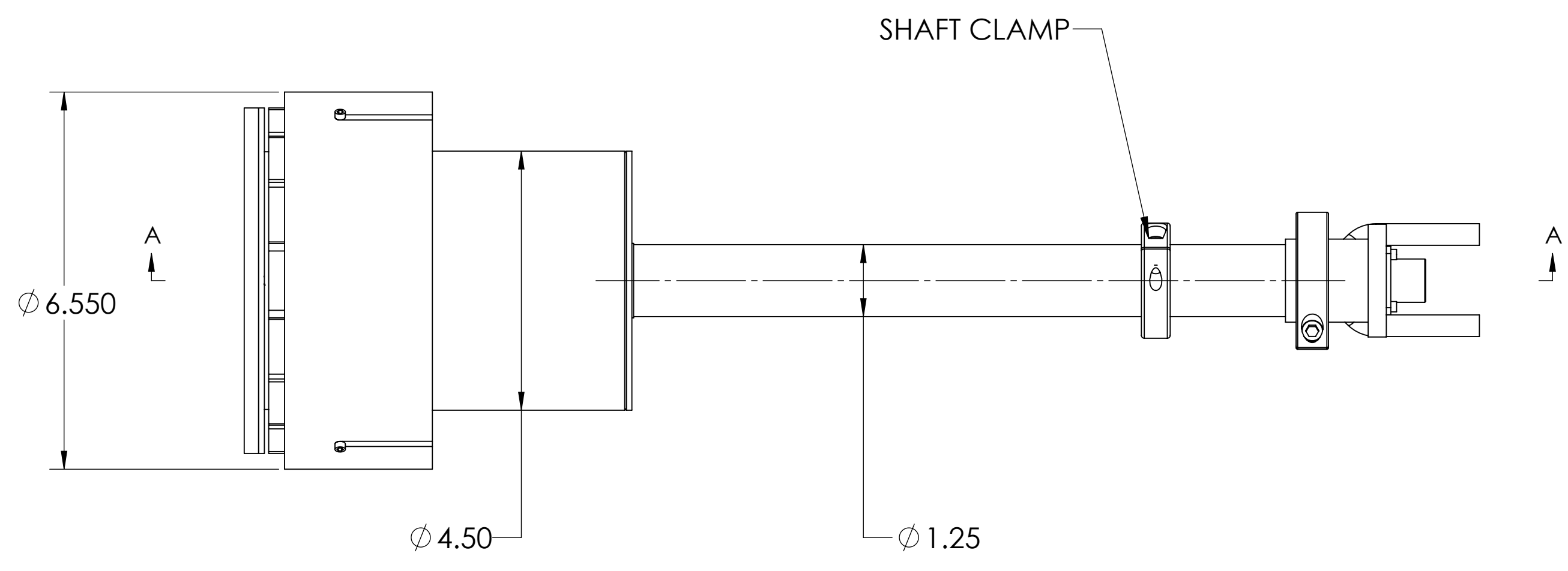
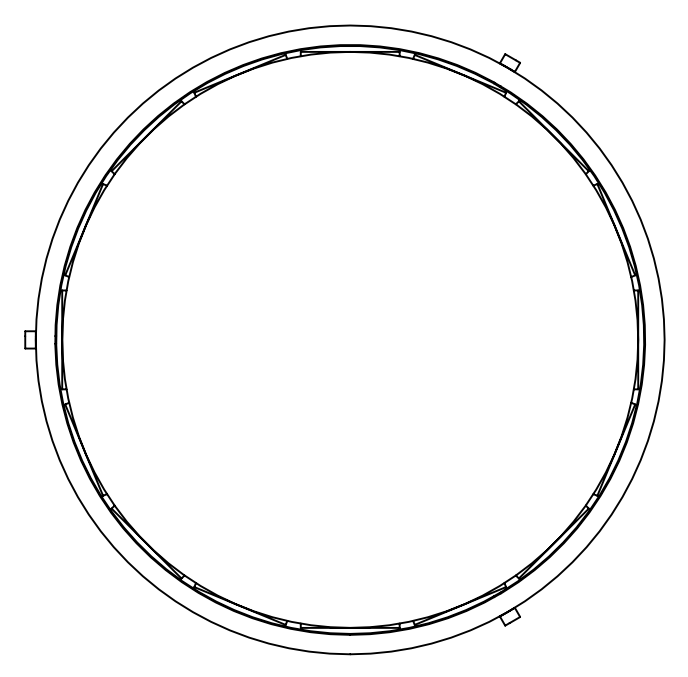
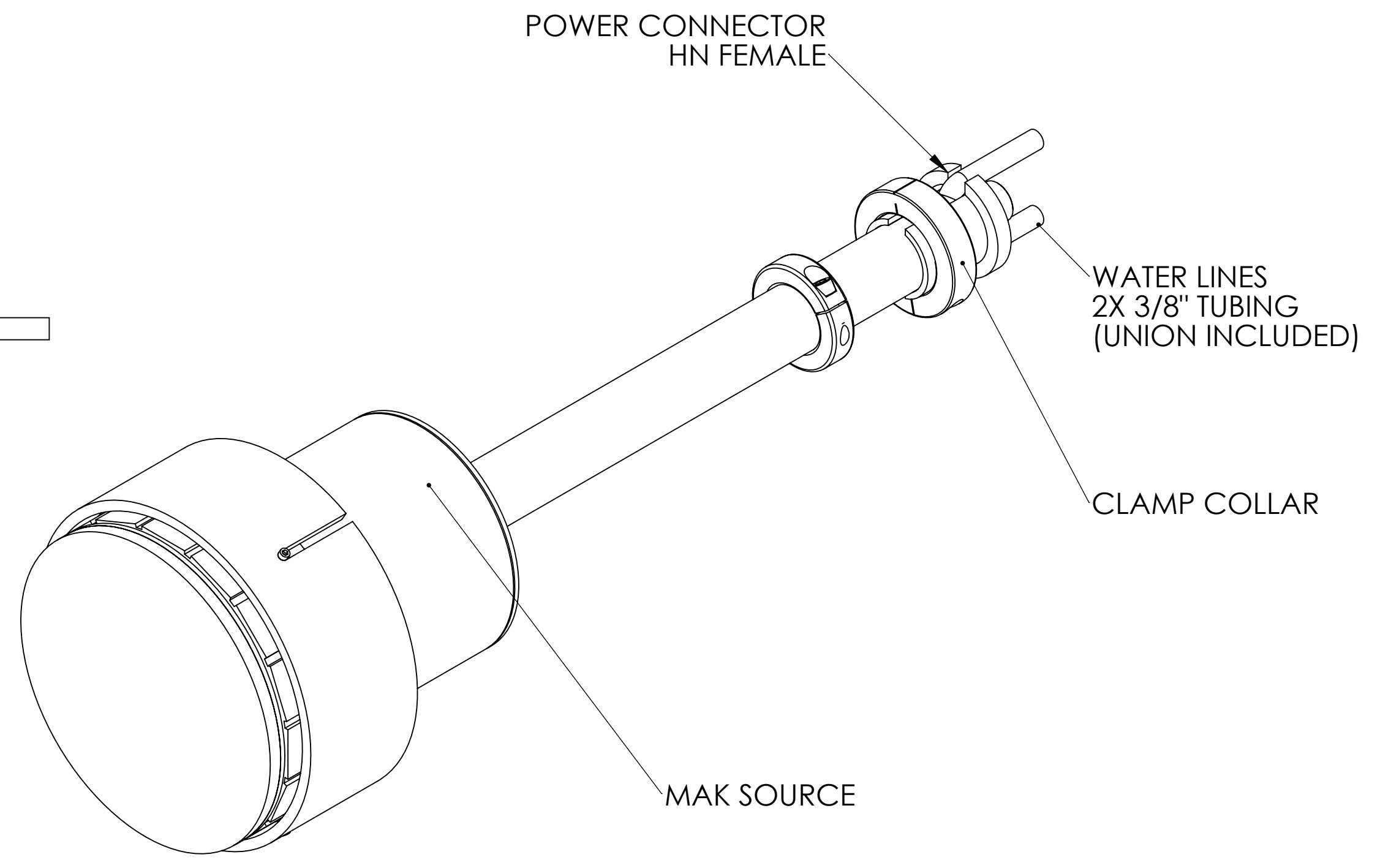

NOTES (UNLESS OTHERWISE SPECIFIED):
 1. 3D MODEL AVAILABLE.

UNLESS OTHERWISE SPECIFIED DIMENSIONS ARE IN INCHES TOLERANCES ARE: DECIMALS .X ± .1 .XX ± .01 .XXX ± .005		ANGLES ±1/2°		THIS DOCUMENT IS THE PROPERTY OF MEIVAC, INC. ITS USE IS AUTHORIZED ONLY FOR RESPONDING TO A REQUEST FOR QUOTATION OR FOR THE PERFORMANCE OF WORK FOR MEIVAC, INC. ALL QUESTIONS MUST BE REFERRED TO MEIVAC ENGINEERING DEPARTMENT.			
MATERIAL: SEE BOM		DRAWN NWM		APPROVALS		DATE 3-22-99	
FINISH: 63		ISSUED		CHECKED		TITLE: 6" MAK SOURCE VERTICAL MOUNT L600	
DO NOT SCALE DRAWING		SCALE: NONE		SIZE D		CAGE CODE	
				DWG. NO. L600A01_EXT		REV E	
				SHEET 1 OF 1		AUTOCAD FILE NAME = L600A01.DWG	